



User and Installation handbook

TropiCal FGIVN



TropiCal FGIVN-035
TropiCal FGIVN-045
TropiCal FGIVN-060
TropiCal FGIVN-070
TropiCal FGIVN-100
TropiCal FGIVN-130

EN

I. DECLARATION OF CONFORMITY	3
II. IMPORTANT SAFETY INSTRUCTIONS (UL 60335-2-40):.....	3
III. DELIVERY AND TRANSPORT	5
IV. DIMENSIONS.....	5
V. TECHNICAL DATA.....	7
VI. INSTALLATION (SITE, TYPE OF SUPPORT, NECESSARY SPACE).....	8
VII. HYDRAULIC CONNECTION.....	9
VIII. ELECTRICAL CONNECTION.....	9
IX. OPERATION AND STARTING OF HEAT PUMP.....	11
X. USE.....	11
XI. SETTINGS	12
XII. GENERAL USE.....	12
XIII. REGULATION (ELECTRONIC CONTROLLER)	14
XIV. MOBILE APPLICATION : MYTECH CONNECT	15
XV. CONTROLLER STATE TABLE.....	16
XVI. QUALIFICATION OF WORKERS (UL 60335-2-40).....	17
XVII. HANDLING INFORMATION	18
XVIII. CLEANING INFORMATION.....	18
XIX. SERVICING (UL 60335-2-40).....	18
XX. DISPOSAL OF REFRIGERANT	20
XXI. REPAIRS TO SEALED COMPONENTS (UL 60335-2-40)	20
XXII. REPAIR TO INTRINSICALLY SAFE COMPONENTS (UL 60335-2-40).....	20
XXIII. CABLING (UL 60335-2-40)	20
XXIV. DETECTION OF FLAMMABLE REFRIGERANTS (UL 60335-2-40).....	20
XXV. REMOVAL AND EVACUATION (UL 60335-2-40)	21
XXVI. CHARGING PROCEDURES (UL 60335-2-40)	21
XXVII. DECOMMISSIONING (UL 60335-2-40)	22
XXVIII. LABELLING (UL 60335-2-40)	22
XXIX. RECOVERY (UL 60335-2-40)	22
XXX. WINTERING	23
XXXI. RECYCLING THE HEAT PUMP	24
XXXII. AFTER-SALES TECHNICAL DEPARTMENT.....	24

I. DECLARATION OF CONFORMITY

Guidelines – Harmonised standards

Tropical

We hereby declare under our sole responsibility that this product complies with the relevant guidelines

SAFETY : UL 60335 and CSA C22.2 NO. 60335-1 and 60335-2-40.

PERFORMANCE : ANSI/AHRI STANDARD 116I-2023 (SI)

Models :

TropiCal FGIVN-035/ TropiCal FGIVN-045/ TropiCal FGIVN-060/ TropiCal FGIVN-070/ TropiCal FGIVN-100/ TropiCal FGIVN-130

Operating temperature: -15°C ~ 43°C

IP: X4

Maximum operating altitude: 2000 m

Power supply : 220 ~ 240 V ~, 60 Hz

Special process of electronic appliances reaching the end of their lifespan:



The symbol depicting a barred waste bin that features on the main parts constituting the product indicates that it must not be discarded alongside household waste. It must be brought to an adequate collection point where electronic appliances are recycled (information available from your local waste treatment service). This product contains potentially hazardous substances.

II. IMPORTANT SAFETY INSTRUCTIONS:

Service indicator; read technical manual



Operator's manual; operating instructions



Read operator's manual.



Flame symbol and A2L Refrigerant



WARNING RELATING APPLIANCES CONTAINING A2L REFRIGERANT:

WARNING

Do not use means to accelerate the defrosting process or to clean, other than those recommended by the manufacturer.

The appliance shall be stored in a room without continuously operating ignition sources (for example: open flames, an operating gas appliance or an operating electric heater).

Do not pierce or burn.

Be aware that refrigerants may not contain an odour.

- The R32 is a refrigerant of category A2L per ISO 817, which is considered as potentially flammable.
- Do not release R32 refrigerant into the atmosphere. This refrigerant is a greenhouse effect fluorinated gas, covered by the Kyoto Protocol, with a global warming potential (GWP) = 675 for R32.
- Be aware that refrigerants may not contain an odour
- Do not use means to accelerate the defrosting process or to clean, other than those recommended by the manufacturer
- The appliance shall be stored in a room without continuously operating ignition sources (for example: open flames, an operating gas appliance or an operating electric heater)

- Do not pierce or burn the appliance.
- Install the unit outdoors. Do not install the unit indoors or in an outdoor area that is closed and poorly ventilated.
- To comply with the relevant standards and regulations in terms of the environment and installation procedures, and in particular with decree N° 2015-1790 and/ or European regulation EU 517/2014, a search for leaks of the cooling circuit must be conducted at least once a year. This operation should be carried out by a certified specialist of cooling devices.
- Please keep and transfer these documents for reference throughout the lifespan of the device, And please save these instructions.

WARNING RELATING USAGE OF THE APPLIANCE:

- In normal conditions, a suitable Heat pump can heat the water of the pool by 1°C to 2°C per day. It is therefore quite normal not to feel a temperature difference at the outlet of the circuit when the Heat pump is operating. A heated pool should be covered to prevent heat losses.
- The appliance is designed to be used in a swimming pool
- Failure to comply with the warnings could cause damage to the swimming pool equipment as well as severe injuries or death.
- Only a qualified person possessing the adequate technical skills (electricity, hydraulic, refrigeration) is authorised to undertake maintenance operations or repairs on the device. A qualified technician working on the device must use/wear personal protective equipment (safety goggles, protection gloves, etc...) To avoid all risk of injury arising during work on the device.
- Prior to any servicing of this device, ensure that it is powered down and has undergone the lockout-tag out procedure.
- The device is designed specifically for use in swimming pools and spas; it must not be used for purposes other than the ones it was designed for.
- This appliance is not intended for use by persons (including children) with reduced physical, sensory or mental capabilities, or lack of experience and knowledge, unless they have been given supervision or instruction concerning use of the appliance by a person responsible for their safety.
- Children must be supervised to ensure that they do not play with the appliance.
- The installation of the device should be carried out according to the manufacturer's instructions and in compliance with local and national applicable standards. The installer is responsible for the installation of the device and for compliance with national regulations relating to installation procedures. The manufacturer will not be liable in case of non-compliance with the installation standards that apply locally.
- For any action other than simple maintenance operations by the user as described in this manual, the product should be maintained by a certified professional.
- Any improper installation and/or use can cause damages and severe injuries (and even death).
- Do not touch the fan or the moving parts, and do not insert objects or your fingers close to the moving parts when the device is operating.
- Moving parts can cause severe injuries and even death.
- Do not pull on the hoses and the connections to move the machine.
- Handling, installation, cleaning, servicing and disposal of refrigerant can only be proceeded by qualified person;

WARNINGS CONCERNING ELECTRICAL APPLIANCES:

- The power supply of the device must be protected by a 30-mA security residual current protection system, as per the standards that apply in the country of installation.
- Do not use an extension to connect the device; only connect the device directly to a suitable power outlet.
- If a fixed device does not feature a power cord and a plug, or any other means to disconnect from the power supply with a separation of the contacts in all the poles, enabling total disconnection in case of a category III electrical surge, the manual will mention that the disconnection means must be integrated in the fixed wiring, as per relevant wiring rules.
- An adapted disconnection method, complying with all local and national requirements relating to category III electrical surges, and that disconnects all the poles of the supply circuit, must be installed in the supply circuit of the device. This disconnection method is not provided with the device and should be provided by the installation technician.
- Prior to installation, check that:
 - The voltage featuring on the information plate of the device matches the voltage of the power supply,
 - The power supply is suitable for operating the device and has an earthing connection.
 - The plug (as necessary) adapts to the plug hole.
- If the power cord is damaged, it should imperatively be replaced by the manufacturer, a technician or a person qualified to ensure safety.

This Heat Pump is listed by ETL as complying with the latest edition of the UL Standard for Safety for electrical heat pumps, air conditioners, and dehumidifiers UL 60335 and CSA C22.2 No. 60335-1 and 60335-2-40.

All Heat Pumps must be installed in accordance with all applicable National and Local codes. In the absence of local codes, refer to the latest edition of the National Electric Code (NEC) in the United States and the Canadian Electric Code (CEC) in Canada.

This product must be installed and serviced by authorized personnel, qualified in pool/spa heater installation. Improper installation and/or operation can cause death, serious injury and/or property damage.

See product rating plate for manufacturer information.

FCC Statement

Changes or modifications not expressly approved by the party responsible for compliance could void the user's authority to operate the equipment.

This equipment has been tested and found to comply with the limits for a Class B digital device, pursuant to Part 15 of the FCC Rules. These limits are designed to provide reasonable protection against harmful interference in a residential installation. This equipment generates uses and can radiate radio frequency energy and, if not installed and used in accordance with the

instructions, may cause harmful interference to radio communications. However, there is no guarantee that interference will not occur in a particular installation. If this equipment does cause harmful interference to radio or television reception, which can be determined by turning the equipment off and on, the user is encouraged to try to correct the interfer-

ence by one or more of the following measures:

- Reorient or relocate the receiving antenna.
- Increase the separation between the equipment and receiver.
- Connect the equipment into an outlet on a circuit different from that to which the receiver is connected.
- Consult the dealer or an experienced radio/TV technician for help

This device complies with part 15 of the FCC rules. Operation is subject to the following two conditions (1) this device may not cause harmful interference, and (2) this device must accept any interference received, including interference that may cause undesired operation.

III. DELIVERY AND TRANSPORT

- When you have unpacked the Heat pump, please check the content to report any damage. Please also check that the pressure reading on the pressure gauge corresponds to the outside temperature, as different values might indicate a leak, depending on the measured outdoor temperature, as different values might indicate a leak.
- The Heat pump should always be stored and transported in a vertical position, on a pallet and inside its original packaging.
- Transporting and/or storing the Heat pump horizontally will void the guarantee.

IV. DIMENSIONS

Tropical IVN-045/ Tropical IVN-055/ Tropical IVN-075/ Tropical IVN-090

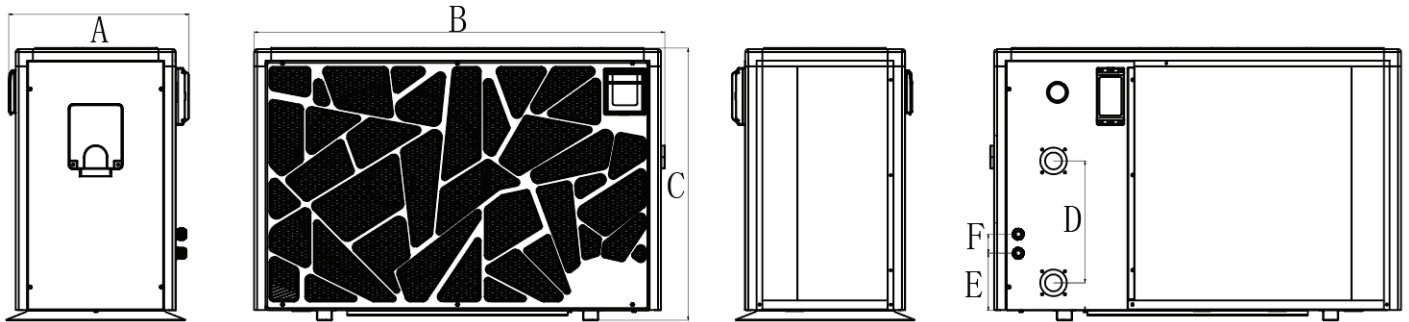

Models	A	B	C	D	E	F
Tropical IVN-035/ Tropical IVN-045	411 mm	980 mm	609 mm	290 mm	151 mm	50 mm
Tropical IVN-060/ Tropical IVN-070	474 mm	1080 mm	715 mm	320 mm	150 mm	50 mm
Tropical IVN-100	518 mm	1178 mm	872 mm	430 mm	210 mm	50 mm

Tropical IVN-090

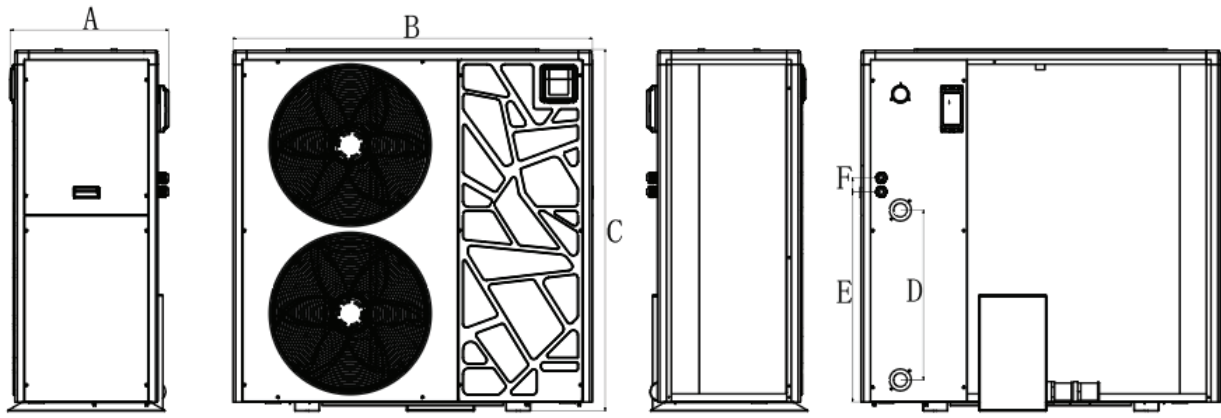

Models	A	B	C	D	E	F
Tropical IVN-130	514 mm	1166 mm	1171 mm	550 mm	681 mm	45 mm

UNDER REVIEW

VI. INSTALLATION (SITE, TYPE OF SUPPORT, NECESSARY SPACE)

- Install the Heat pump outdoors at more than 6ft (1.83 meters) from the inside wall of the pool, according to National and Local codes.
- Place the Heat pump on the provided vibration absorbers on a surface that is stable, solid (able to bear the weight of the device) and level (prepare a concrete base if necessary).
- Maintain 1 m (30 cm minimum) of open space in front of the vertical air intake grids (behind and on the side of the Heat pump) and 3 m at the outlet of the fan (in front) of open space without any obstacles.
- Prepare sufficient space around the Heat pump for maintenance operations.
- Prepare a water evacuation system close to the Heat pump to protect the installation zone.
- Keep the Heat pump out of the reach of children, insofar as possible.

The Heat pump should never be installed:

- In an area covered by sprinkling systems, or subject to spray or running water or mud (close to a road, take into account the effects of wind),
- Under a tree,
- Close to a source of heat or of flammable gas,
- In an area where it would be exposed to oil, flammable gases, corrosive products, and compounds containing sulphur,
- Close to equipment operating at high frequencies,
- In a place where snow is likely to accumulate,
- In a place where it could be flooded by the condensates produced by the device as it operates,
- On a surface that could transfer the vibrations to the house.

Advice: dampen the possible noise nuisance caused by your Heat pump.

- Do not install it close to or underneath a window.
- Do not direct the outlet of the fan towards your neighbors' property.
- Do not direct the fan outlet (cold air) towards the swimming pool.
- Install it in an open area (sound waves bounce off surfaces).
- Install 50 cm of PVC piping at the water inlet and outlet of the Heat pump.

The Heat pump must be installed and maintained on a fixed and solid basis, with the skids placed under the feet.

- For concrete, use adapted \varnothing 8 mm lag screws fitted with washers to prevent any loosening.

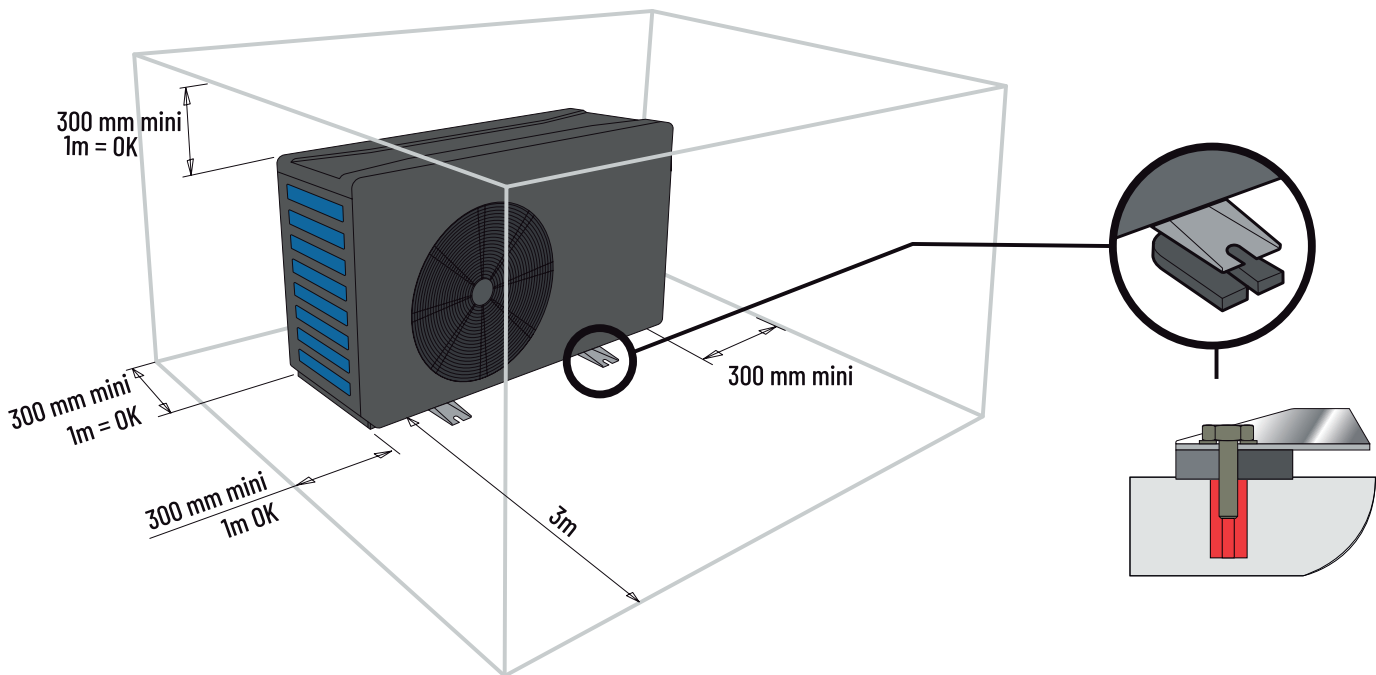

VII. HYDRAULIC CONNECTION

- Water quality necessary for this device must comply with The Model Aquatic Health Code ANSI/APSP/ICC-15 2019
- The Heat pump is compatible with all types of water treatment. The Heat pump must be connected by a PVC pipe of Ø 50mm to the swimming pool's hydraulic
- Circuit, after the filter and before the treatment system, regardless of its type (Cl, pH, Br metering pumps and/or electrolyzer).
- Follow the hydraulic connection order (blue = water in, red = water out)
- A bypass must be installed to facilitate work on the Heat pump.
- Before connecting the PVC pipes to the Heat pump, make sure the circuit is clean of any work residue (stone, soil, etc.).

Connection of the condensate evacuation pack:

During operations, the Heat pump is subject to a condensation phenomenon. This translates into a water flow, which can be more or less important depending on the degree of humidity. To channel this flow, which can represent several litres/ gallons of water per day, we recommend you install the provided condensate evacuation pack and connect it to a suitable water evacuation circuit.

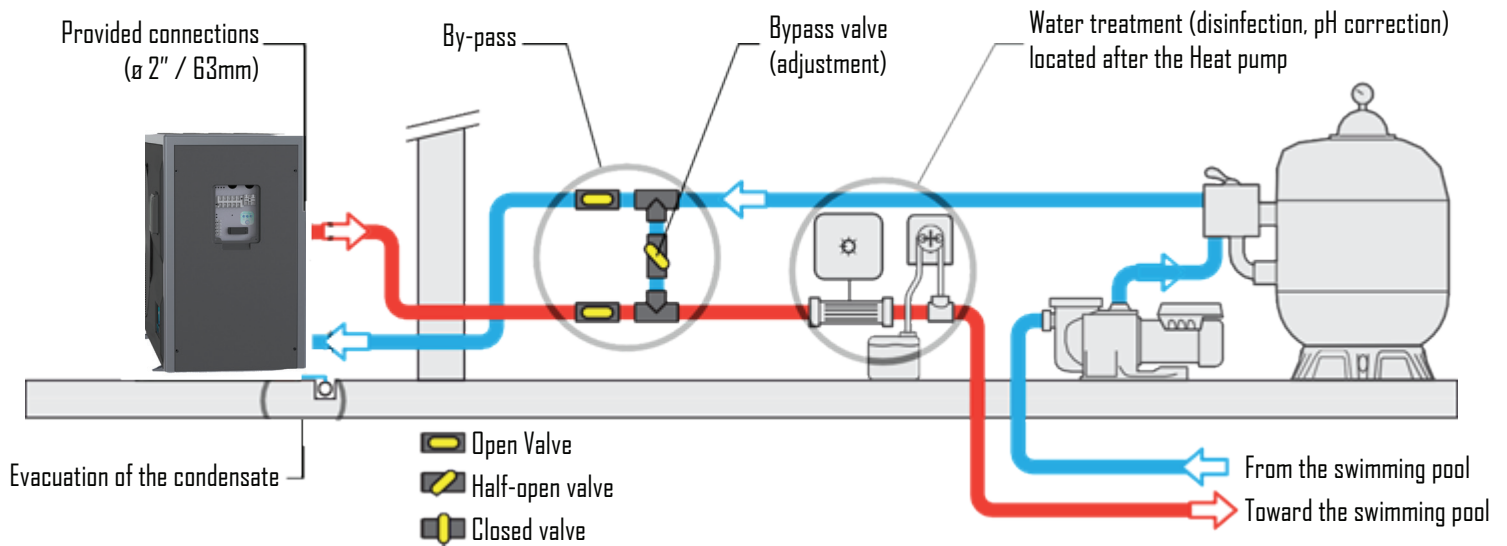

VIII. ELECTRICAL CONNECTION

Connection of the power supply:

Prior to undertaking any servicing inside the Heat pump, it is imperative to disconnect the power supply from the Heat pump; there is a risk of electrocution that can cause damages, severe injuries and even death.

- Only a certified and experienced technician is authorised to conduct cabling work in an Heat pump or to replace the power cable.
- the power supply should match the voltage featuring on the information plate of the Heat pump.
- The Heat pump must be connected to an earthing connection.

Electrical Installation:

To ensure safe operations and to protect the integrity of your electric installation, the Heat pump should be connected to the electrical mains according to the following rules:

- Use electrical supply wires suitable for 60°C/140°F
- Upstream, the electrical mains should be protected by a 30-mA differential switch.
- The Heat pump should be connected to a suitable circuit-breaker (see the table below) according to the standards and regulations in force in the country where the system is installed.
- It is recommended to crimp the electric cables on lugs adapted to the diameter of the cable chosen before connecting them to the Heat pump
- The power cord should be adapted to the power of the Heat pump and the length of cable required for the installation (see the table below). The cable must be suitable for outdoor use.

The connections must be sized based on the power of the Heat pump and on the installation state.

Model	Power supply	MCA (Minimum circuit ampacity)	MOP (Maximum overcurrent protection)	Overcurrent protection device (breaker or fuses)	Select wire size per local codes	Rated temperature rise
FGINV-035	220 V/ 60Hz	8,7 A	14,5 A	15 A	---	60°C - 140°F
FGINV-045	220 V/ 60Hz	10,8 A	18,2 A	20 A	---	60°C - 140°F
FGINV-060	220 V/ 60Hz	13,1 A	22,4 A	25 A	---	60°C - 140°F
FGINV-070	220 V/ 60Hz	13,1 A	22,4 A	25 A	---	60°C - 140°F
FGINV-100	220 V/ 60Hz	26,7 A	46,8 A	50 A	---	60°C - 140°F
FGINV-130	220 V/ 60Hz	27,4 A	47,9 A	50 A	---	60°C - 140°F

It is recommended to use wire terminal for better electrical contact between wire and power supply terminal. These data are only indicative, you must ask an electrician to determine the exact data for your pool installation. Power supply must be equipped with grounding and 30 mA differential protection.

- Use the cable-gland and the pass-through provided inside the Heat pump for the passage of the cable.
- As this heat pump is installed outdoors, it is mandatory to pass the cable through a protective sheath for this purpose. The power supply of the Heat pump must be fitted with a protection device in accordance with the legislation in force.

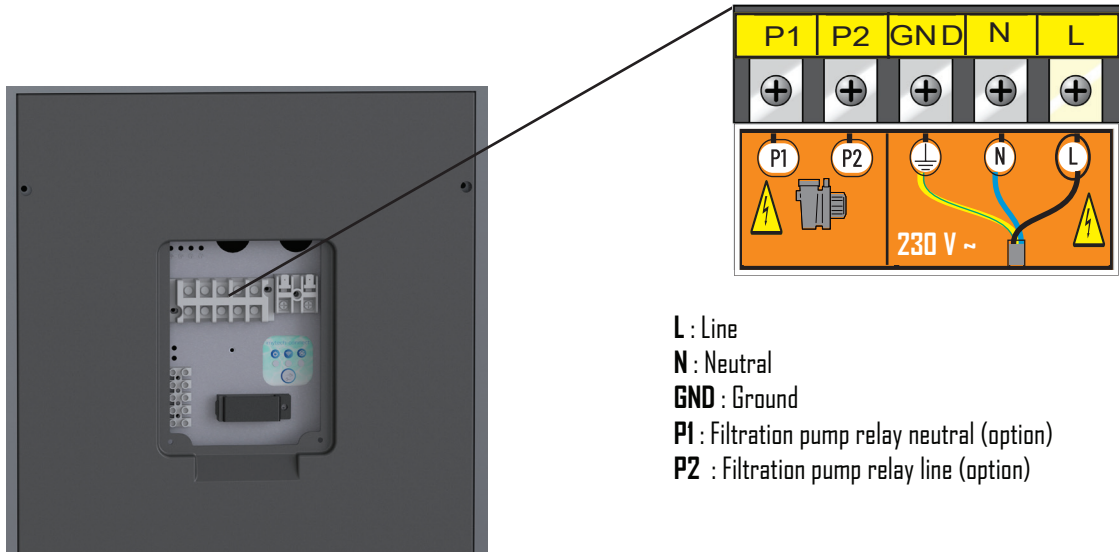

Automation

You have a very low voltage terminal block to which you can connect your home automation. This is an ON / OFF dry contact. Remove the existing bridge. When your home automation opens this contact, the machine stops and displays the message: No flow.

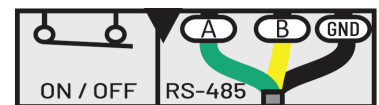

Heating priority (Option):

The filtration pump can be connected to the Heat pump to force the filtration to operate if the water is not at the desired temperature. Prior to this connection, a “dry contact” (normally open relay or connector) with a 230V AC coil should be provided.

Electrical connections:

- Connect the coil of this relay (A1 and A2) on the P1 and P2 terminals of the Heat pump.
- Connect the input and the output of the dry contact (normally open) in parallel with the dry contact of the filtration clock of the swimming pool.

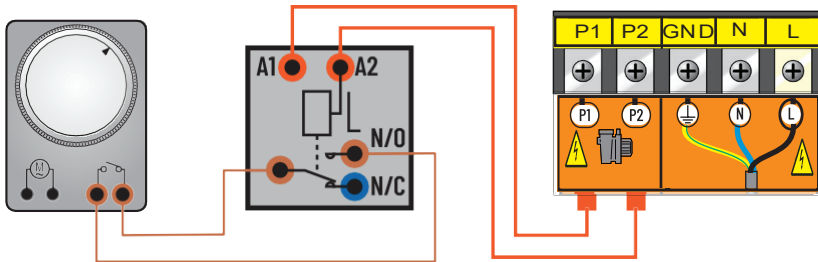

Parameter for taking the connection into account: Check that the setting of the filtration pump parameter (parameter #9) is set to «2». If this is not the case, please contact us to change the setting.

IX. OPERATION AND STARTING OF HEAT PUMP

Once the Heat pump is connected to the water circuit with the bypass, and is connected to the power supply by a professional, ensure that:

- The Heat pump is horizontal (level).
- The Heat pump is secured and stable.
- The water circuit has been purged of air that has been trapped in the piping of the Heat pump.
- The pressure gauge, at the back of the Heat pump, shows a temperature that is equal to the ambient outdoor temperature.
- The water circuit is properly connected (no leaks or damage to the hydraulic connections, the connections are properly tightened).
- The electric circuit is properly connected (the cables are tightly secured to the terminals and intermediate circuit-breaker), properly insulated, and connected to the earthing connection.
- The conditions of installation and use described above have all been met.
- The outdoor temperature is between -15 and +43°C.
- The water temperature is of 15°C minimum.
- The evaporator at the rear/on the sides of the Heat pump is clean (leaves, dust, pollen, cobwebs...)

You can now start your device by following, in the given order, the following steps:

- Open the 3 valves of the bypass (refer to the hydraulic diagram).
- Half-close the bypass valve.
- Remove all unused items or tools from the area surrounding the Heat pump.
- Start the pump of the filtration system.
- Power up the Heat pump by engaging the circuit-breaker and using the ON/OFF button of the display.
- Check that the Heat pump starts and stops in sync with the filtration circuit: if no water is detected in the Heat pump, the display shows “FLO”
- The Heat pump starts after a delay of a few minutes.
- Adjust the temperature (“Regulation” chapter).
- Adjust the water flow (“Water flow setting” chapter).
- After a few minutes, you can adjust the bypass valve as indicated in the “Water flow setting” chapter. Having completed the above steps, cover the pool and let the Heat pump operate for a few days with the filtration pump in “forced mode” until the water of the pool reaches the desired bathing temperature.

X. USE

- Cover the pool with a cover (bubble cover, shutter...) to reduce heat losses.

XI. SETTINGS

Water flow setting:

- To optimize the heating performance and achieve power savings, the flow of water travelling through the Heat pump should be adjusted.
- The adjustment is done based on the reading of the adjustment pressure gauge. The adjustment is done by opening or closing the adjustment valve of the bypass.
- To increase the pressure on the front pressure gauge: reduce the amount of water passing through the Heat pump: open the bypass adjustment valve.
- To reduce the pressure on the front pressure gauge: increase the amount of water passing through the Heat pump: close the bypass adjustment valve.
- During normal operations, the inlet and outlet valves must remain fully open.

Normal pressure:

- The flow of water through the Heat pump and the refrigerant pressure in the device are intimately linked.
- The flow value given for information purposes is of 5 to 7m³/h, i.e. approximately 100l/min to reach the maximum heating power of the Heat pump.
- The ideal setting is achieved when the hand of the pressure gauge (for heating operations in MAX mode) indicates a temperature in °C greater by 10 to 15°C than the current temperature of the swimming pool.
- Remember, the Heat pump must operate for a few minutes before the pressure stabilizes on the pressure gauge.
- Example: the swimming pool water is 20°C, the Heat pump has been operating for 5 minutes, and the hand of the pressure gauge indicates 20 bars / 280 PSI / 32°C / 90°F. -> 32°C - 20°C = 12°C -> the setting is right (between 10 and 15°C).

Abnormal pressure:

- If the pressure at the pressure gauge is too high or too low, that means that the flow of water through the Heat pump is inadequate.
- Action must therefore be taken by opening or closing progressively the bypass adjustment valve, to get the pressure in the recommended range.
- When stopped, the temperature reading should be close to the temperature of the swimming pool water.
- If the hand shows 0, the device should not be used (contact your distributor).

Setting frequency:

- The flow through the Heat pump depends much on water temperature, and to a lesser extent, on air temperature. It should therefore be adjusted:
 - When the pump is started, and the water is cold;
 - During the rise of temperature;
 - When the desired temperature has been reached.

There should not be any reason to subsequently adjust the flow. An occasional reading of the pressure gauge to ensure everything is operating normally and the flow remains unchanged is generally sufficient.

XII. GENERAL USE

Water quality (standard):

The water quality standards must respect the following norms:

- Chlorine concentration less than 2.5 ppm
- pH between 6.9 and 8
- In case of sudden chlorination, isolate the heat pump by shutting the inlet and outlet valves of the device, and reset them to their initial positions after treatment.

Rise in temperature :

As soon as you want to put your pool into service at the beginning of the season:

- First isolate your heat pump from the filtration circuit:
- Close the upstream and downstream valves of the bypass.
- Fully open the adjusting valve.
- Carry out all the usual initial operations (filling, treatment, washing the filter, etc.).
- Turn on the filtration pump.
- Turn on the heat pump, set the temperature, open the valves and adjust the water flow.
- Cover the pool with isothermal pool cover.
- Allow the filtration pump and heat pump to run continuously until the desired temperature is reached (2 days to 1 week depending on climatic and geographical conditions).

Remember to adjust the flow rate during and at the end of the temperature rise.

The temperature rise time depends heavily on the exposure of the pool to the wind, sun and the nature of its environment.

Maintaining the temperature:

- Once the desired temperature has been reached, you can set the daily filtration time according to your habits (8 to 10 hours per day minimum during the season).

The heat pump will start automatically whenever necessary. The minimum operating time varies based on the time of use, please contact your distributor for further information.

If you notice the water temperature of the pool is falling, despite the device operating continuously, increase the daily filtration time.

Do not forget to cover the pool with an insulated cover when you are not using it, to limit heat losses.

IMPORTANT: a swimming pool without a cover will lose 4 times more energy than the same pool with a cover.

The choice of the heat pump should always take into account the presence of a tarpaulin, a rolling shutter, or any other type of protection of the pool when it is not being used.

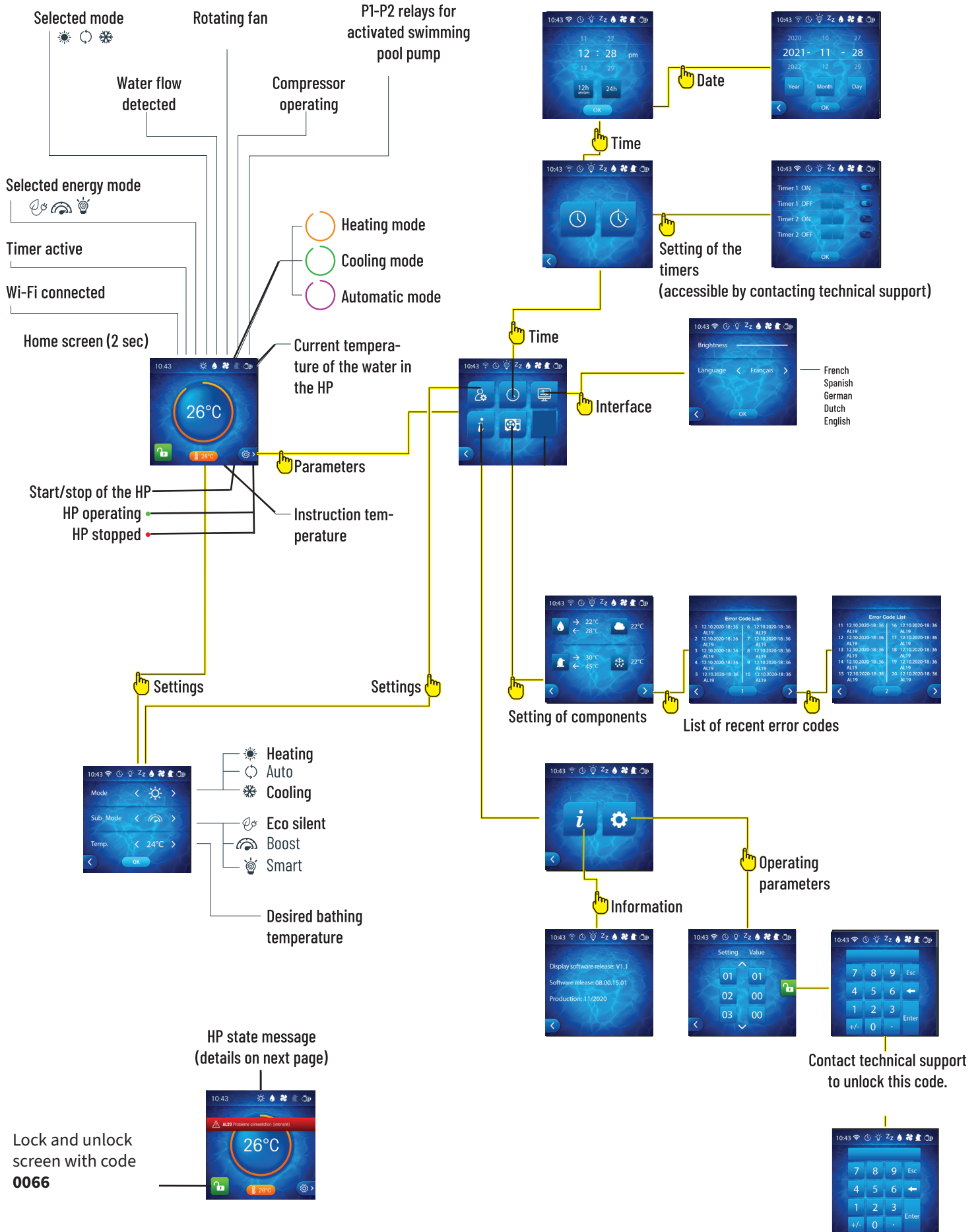

This model is equipped with Mytech connect module allowing the user to control remotely the heat pump and its accessories with **Mytech connect application**.

Mytech connect will also allow you to communicate easily with our after sales technicians to solve remotely and quickly some of the machine disfuncions.

Download the App

On apple or android store download the app, thanks to the Qr code located behind the electrical supply access hatch or below the nameplate of the machine.



Behind the access hatch



Near the nameplate

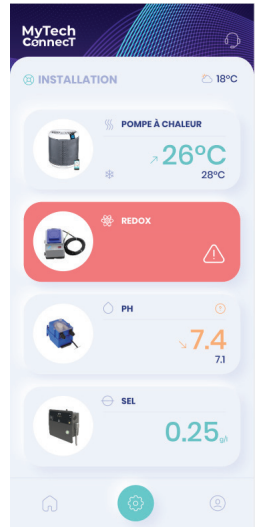
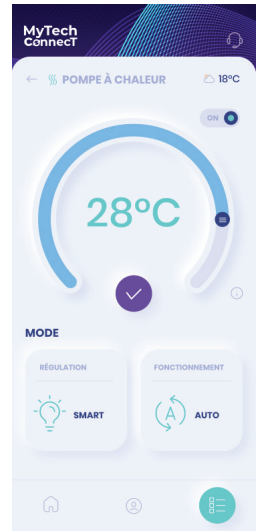
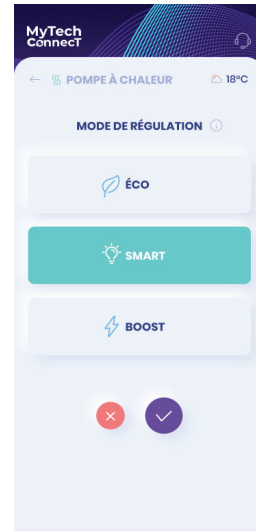
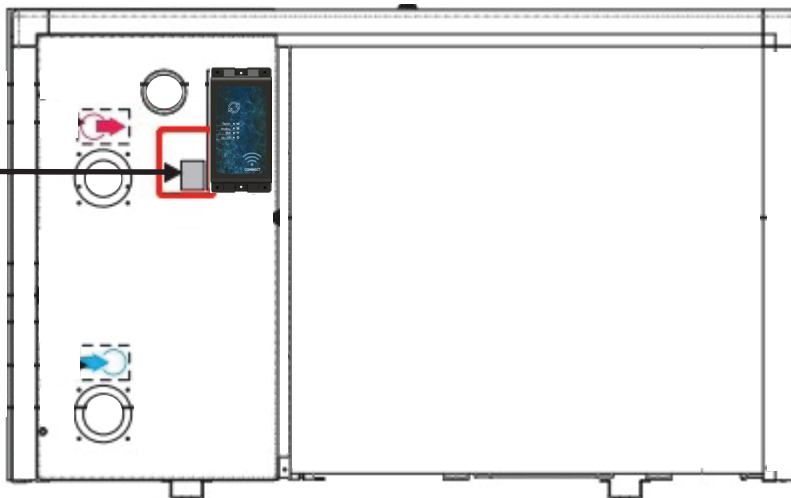

XV. CONTROLLER STATE TABLE

Fault code	Explanation	Check	Solution (if no reset)
St-by	Stand-by		
FLO	No water flow or the flow switch doesn't detect the water flow	- Check if filtration pump is working. - Check by-pass setting. - Check water flow switch position.	Contact your seller
AL10 / AL11	Heat pump error		
AL15 / AL16	Too much temperature difference between water in and water out.		
AL18	Comp. Out temp. Too high		
AL17	Low temp protection in cooling mode		
AL7 / AL8	Communication error	Check electrical connection between controller and electronic card inside the machine.	
AL3	Probe error (Water in)	Check probe connection.	
AL4	Probe error (Water out)		
AL5	Probe error (coil.)		
AL1	Probe error (comp. out)		
AL2	Probe error (comp. in)		
AL6	Probe error (ambiance)		
AL9	Fan error	Check fan connection.	
AL14	Outdoor temperature too low	Outdoor temp is below -15°C	Wait for the outdoor temperature to increase.
AL19 / AL20	Power supply problem	Ask an electrician specialist to check power supply.	Contact your seller
AL21 / AL22 / AL23 / AL24 / AL25	Electronic/overheating protection	Stop the power supply for 5 to 10 minutes, check that air flow is not blocked, turn ON power supply	

General:

Information of procedures additional to usual information for refrigerating appliance installation, repair, maintenance and decommission procedures is required when an appliance with FLAMMABLE REFRIGERANTS is affected.

The training of these procedures is carried out by national training organizations or manufacturers that are accredited to teach the relevant national competency standards that may be set in legislation. The achieved competence should be documented by a certificate.

Only qualified service technicians should perform any work/ repairs on the heat pump.

Information and training:

The training should include the substance of the following:

- Information about the explosion potential of FLAMMABLE REFRIGERANTS to show that flammables may be dangerous when handled without care.
- Information about POTENTIAL IGNITION SOURCES, especially those that are not obvious, such as lighters, light switches, vacuum cleaners, electric heaters.
- Information about the different safety concepts: Safety of the appliance depends on ventilation of the housing. Switching off the appliance or opening of the enclosure has a significant effect on the safety. Care should be taken to ensure sufficient ventilation before.
- Information about refrigerant detectors:
 - Principle of function, including influences on the operation.
 - Procedures, how to repair, check or replace a refrigerant detector or parts of it in a safe way.
 - Procedures, how to disable a refrigerant detector in case of repair work on the refrigerant carrying parts.
- Information about the concept of sealed components and sealed enclosures according to IEC 60079-15:2010.
- Information about the correct working procedures:
 - a. Commissioning
 - Ensure that the floor area is sufficient for the REFRIGERANT CHARGE or that the ventilation duct is assembled in a correct manner.
 - Connect the pipes and carry out a leak test before charging with refrigerant
 - Check safety equipment before putting into service
 - b. Maintenance
 - Portable equipment shall be repaired outside or in a workshop specially equipped for servicing units with FLAMMABLE REFRIGERANTS.
 - Ensure sufficient ventilation at the repair place.
 - Be aware that malfunction of the equipment may be caused by refrigerant loss and a refrigerant leak is possible.
 - Discharge capacitors in a way that won't cause any spark. The standard procedure to short circuit the capacitor terminals usually creates sparks.
 - Reassemble sealed enclosures accurately. If seals are worn, replace them. Check safety equipment before putting into service.
 - c. Repair
 - Portable equipment shall be repaired outside or in a workshop specially equipped for servicing units with FLAMMABLE REFRIGERANTS.
 - Ensure sufficient ventilation at the repair place.
 - Be aware that malfunction of the equipment may be caused by refrigerant loss and a refrigerant leak is possible.
 - Discharge capacitors in a way that won't cause any spark.
 - When brazing is required, the following procedures shall be carried out in the following order:
 - Safely remove the refrigerant following local and national regulations. If the recovery is not required by national regulations, drain the refrigerant to the outside. Take care that the drained refrigerant will not cause any danger. In doubt, one person should guard the outlet. Take special care that drained refrigerant will not float back into the building;
 - Purge the refrigerant circuit with oxygen free nitrogen;
 - Evacuate the refrigerant circuit;
 - Purge the refrigerant circuit with nitrogen for 5 min (not required for A2L refrigerants).
 - Evacuate again (not required for A2L refrigerants).
 - Remove parts to be replaced by cutting or brazing.
 - Purge the braze point with nitrogen during the brazing procedure required for repair
 - Carry out a leak test before charging with refrigerant.
 - d. Decommissioning
 - If the safety is affected when the equipment is put out of service, the REFRIGERANT CHARGE shall be removed before decommissioning
 - Ensure sufficient ventilation at the equipment location.

- Be aware that malfunction of the equipment may be caused by refrigerant loss and a refrigerant leak is possible.
 - Discharge capacitors in a way that won't cause any spark
 - Remove the refrigerant. If the recovery is not required by national regulations, drain the refrigerant to the outside. Take care that the drained refrigerant will not cause any danger. In doubt, one person should guard the outlet. Take special care that drained refrigerant will not float back into the building
 - When FLAMMABLE REFRIGERANTS except A2L REFRIGERANTS are used,
 - Evacuate the refrigerant circuit.
 - Purge the refrigerant circuit with nitrogen for 5 min. -Evacuate again.
 - Fill with nitrogen up to atmospheric pressure.
 - Put a label on the equipment that the refrigerant is removed.
- e. Disposal
- Ensure sufficient ventilation at the working place
 - Remove the refrigerant. If the recovery is not required by national regulations, drain the refrigerant to the outside. Take care that the drained refrigerant will not cause any danger. In doubt, one person should guard the outlet. Take special care that drained refrigerant will not float back into the building
 - When flammable refrigerants are used,
 - evacuate the refrigerant circuit.
 - purge the refrigerant circuit with oxygen free nitrogen.
 - evacuate again. (not required for A2L refrigerants); and
 - cut out the compressor and drain the oil.
 - Cut out the compressor and drain the oil.

XVII. HANDLING INFORMATION

The unit can only be handled by a qualified person.

Do not handle the heat pump when the power is activated.

Do not handle the heat pump before disconnecting the water inlet and outlet pipes.

The Heat pump should always be stored and transported in a vertical position on a pallet and inside its original packaging.

Transporting and/or storing the Heat pump horizontally will void the guarantee.

XVIII. CLEANING INFORMATION

Deactivate power while cleaning the heat pump.

Clean the evaporator with a soft brush or water jet.

Do not use high pressure cleaner.

Check condenser cleanliness.

Use soft soap and water to clean the heat pump casing.

Do not use solvents.

XIX. SERVICING (UL 60335-2-40)

General :

Every working procedure that affects safety means shall only be carried out by competent persons.

Before any maintenance operation, the heat pump must be completely stopped for few minutes before connecting pressure controllers. This is because high pressure and temperature inside the heat pump could be harmful.

Please check the following on a monthly basis:

- Check and clean the evaporator (with a soft brush or water jet).
- Do not use high pressure cleaner.
- Check all electrical and ground connections.
- Check that all electrical connections and terminals are securely connected.
- Check gas pressure (when heat pump is stopped, manometer must indicate a pressure higher than 0.5)

Please check the following points yearly:

- Check settings.
- Check securities.
- Check all electrical connections and ground.
- Check condenser cleanliness.
- Use soft soap and water to clean the heat pump casing, do not use solvents.

Prior to beginning work on systems containing flammable refrigerants, safety checks are necessary to ensure that the risk of ignition is minimised. For repair to the refrigerating system, the following rules shall be respected prior to conducting work on the system.

Work procedure :

Work shall be undertaken under a controlled procedure so as to minimise the risk of a flammable gas or vapour being present while the work is being performed.

General work area :

All maintenance staff and others working in the local area shall be instructed on the nature of work being carried out. Work in confined spaces shall be avoided.

Checking for presence of refrigerant :

The area shall be checked with an appropriate refrigerant detector prior to and during work, to ensure the technician is aware of potentially toxic or flammable atmospheres. Ensure that the leak detection equipment being used is suitable for use with all applicable refrigerants, i.e. non-sparking, adequately sealed or intrinsically safe.

Presence of fire extinguisher :

If any hot work is to be conducted on the refrigerating equipment or any associated parts, appropriate fire extinguishing equipment shall be available to hand. Have a dry powder or CO₂ fire extinguisher adjacent to the charging area

No ignition sources :

No person carrying out work in relation to a refrigerating system which involves exposing any pipe work shall use any sources of ignition in such a manner that it may lead to the risk of fire or explosion. All possible ignition sources, including cigarette smoking, should be kept sufficiently far away from the site of installation, repairing, removing and disposal, during which refrigerant can possibly be released to the surrounding space. Prior to work taking place, the area around the equipment is to be surveyed to make sure that there are no flammable hazards or ignition risks. "No Smoking" signs shall be displayed.

Ventilated area :

Ensure that the area is in the open or that it is adequately ventilated before breaking into the system or conducting any hot work.

A degree of ventilation shall continue during the period that the work is carried out.

The ventilation should safely disperse any released refrigerant and preferably expel it externally into the atmosphere.

Checks to the refrigeration equipment

- Where electrical components are being changed, they shall be fit for the purpose and to the correct specification.
- At all times the manufacturer's maintenance and service guidelines shall be followed. If in doubt, consult the manufacturer's technical department for assistance.
- The following checks shall be applied to installations using FLAMMABLE REFRIGERANTS:
 - the actual REFRIGERANT CHARGE is in accordance with the room size within which the refrigerant containing parts are installed;
 - the ventilation machinery and outlets are operating adequately and are not obstructed;
 - if an indirect refrigerating circuit is being used, the secondary circuit shall be checked for the presence of refrigerant;
 - marking to the equipment continues to be visible and legible. Markings and signs that are illegible shall be corrected;
 - refrigerating pipe or components are installed in a position where they are unlikely to be exposed to any substance which may corrode refrigerant containing components, unless the components are constructed of materials which are inherently resistant to being corroded or are suitably protected against being so corroded.

Checks to electrical devices

- Repair and maintenance to electrical components shall include initial safety checks and component inspection procedures.
- If a fault exists that could compromise safety, then no electrical supply shall be connected to the circuit until it is satisfactorily dealt with.

- If the fault cannot be corrected immediately but it is necessary to continue operation, an adequate temporary solution shall be used.
- This shall be reported to the owner of the equipment so all parties are advised.
- Initial safety checks shall include:
 - That capacitors are discharged: this shall be done in a safe manner to avoid possibility of sparking;
 - That no live electrical components and wiring are exposed while charging, recovering or purging the system;
 - That there is continuity of earth bonding.

Refrigerant pipe work :

- The installation of pipe-work shall be kept to a minimum;
- Pipe-work including piping material, pipe routing, and installation shall include protection from physical damage in operation and service, and be in compliance with national and local codes and standards, such as ASHRAE 15, ASHRAE 15.2, IAPMO Uniform Mechanical Code, ICC International Mechanical Code, or CSA B52. All field joints shall be accessible for inspection prior to being covered or enclosed;
- after completion of field piping for split systems, the field pipework shall be pressure tested with an inert gas and then vacuum tested prior to refrigerant charging, according to the following requirements;
- The minimum test pressure for the low side of the system shall be the low side design pressure and the minimum test pressure for the high side of the system shall be the high side design pressure, unless the high side of the system, cannot be isolated from the low side of the system in which case the entire system shall be pressure tested to the low side design pressure.
- field-made refrigerant joints indoors shall be tightness tested. The test method shall have a sensitivity of 5 grams per year of refrigerant or better under a pressure of at least 0.25 times the maximum allowable pressure. No leak shall be detected;

XX. DISPOSAL OF REFRIGERANT

- Ensure sufficient ventilation at the working place
- Remove the refrigerant. If the recovery is not required by national regulations, drain the refrigerant to the outside. Take care that the drained refrigerant will not cause any danger. In doubt, one person should guard the outlet. Take special care that drained refrigerant will not float back into the building
- When flammable refrigerants are used,
 - evacuate the refrigerant circuit.
 - purge the refrigerant circuit with oxygen free nitrogen.
 - evacuate again.(not required for A2L refrigerants);and
 - cut out the compressor and drain the oil.
 - Cut out the compressor and drain the oil.

XXI. REPAIRS TO SEALED COMPONENTS (UL 60335-2-40)

1. During repairs to sealed components,all electrical supplies shall be disconnected from the equipment being worked upon prior to any removal of sealed covers,etc.If it is absolutely necessary to have an electrical supply to equipment during servicing,then a permanently operating form of leak detection shall be located at the most critical point to warn of a potentially hazardous situation.
2. Sealed electrical components shall be replaced.

XXII. REPAIR TO INTRINSICALLY SAFE COMPONENTS (UL 60335-2-40)

1. Do not apply any permanent inductive or capacitance loads to the circuit without ensuring that this will not exceed the permissible voltage and current permitted for the equipment in use.
2. Intrinsically safe components must be replaced.
3. Replace components only with parts specified by the manufacturer. Other parts may result in the ignition of refrigerant in the atmosphere from a leak.

NOTE : THE USE OF SILON SEALANT CAN INHIBIT THE EFFECTIVENESS OF SOME TYPES OF LEAK DETECTION EQUIPMENT.INTRINSICALLY SAFE COMPONENTS DO NOT HAVE TO BE ISOLATED PRIOR TO WORKING ON THEM.

XXIII. CABLING (UL 60335-2-40)

Check that cabling will not be subject to wear,corrosion,excessive pressure,vibration,sharp edges or any other adverse environmental effects.The check shall also take into account the effects of aging or continual vibration from sources such as compressors or fans.

XXIV. DETECTION OF FLAMMABLE REFRIGERANTS (UL 60335-2-40)

Under no circumstances shall potential sources of ignition be used in the searching for or detection of refrigerant leaks. A halide torch (or any other detector using a naked flame) shall not be used.

The following leak detection methods are deemed acceptable for all refrigerant systems.

Electronic leak detectors may be used to detect refrigerant leaks but, in the case of FLAMMABLE REFRIGERANTS, the sensitivity may not be adequate, or may need recalibration. (Detection equipment shall be calibrated in a refrigerant-free area.) Ensure that the detector is not a potential source of ignition and is suitable for the refrigerant used. Leak detection equipment shall be set at a percentage of the LFL of the refrigerant and shall be calibrated to the refrigerant employed, and the appropriate percentage of gas (25% maximum) is confirmed.

Leak detection fluids are also suitable for use with most refrigerants but the use of detergents containing chlorine shall be avoided as the chlorine may react with the refrigerant and corrode the copper pipe-work.

NOTE: EXAMPLES OF LEAK DETECTION FLUIDS ARE :

- BUBBLE METHOD,
- FLUORESCENT METHOD AGENTS.

If a leak is suspected, all naked flames shall be removed/extinguished.

If a leakage of refrigerant is found which requires brazing, all of the refrigerant shall be recovered from the system, or isolated (by means of shut off valves) in a part of the system remote from the leak.

XXV. REMOVAL AND EVACUATION (UL 60335-2-40)

When breaking into the refrigerant circuit to make repairs or for any other purpose conventional procedures shall be used.

However, for FLAMMABLE REFRIGERANTS it is important that best practice is followed since flammability is a consideration.

The following procedure shall be adhered to:

- Safely remove refrigerant following local and national regulations;
- Evacuate
- Purge the circuit with inert gas (optional for A2L);
- Evacuate (optional for A2L);
- Continuously flush or purge with inert gas when using flame to open circuit;
- Open the circuit by cutting or brazing.

The refrigerant charge shall be recovered into the correct recovery cylinders if venting is not allowed by local and national codes.

For appliances containing flammable refrigerants, the system shall be purged with oxygen-free nitrogen to render the appliance safe for flammable refrigerants.

This process might need to be repeated several times. Compressed air or oxygen shall not be used for purging refrigerant systems.

For appliances containing flammable refrigerants, refrigerants purging shall be achieved by breaking the vacuum in the system with oxygen-free nitrogen and continuing to fill until the working pressure is achieved, then venting to atmosphere, and finally pulling down to a vacuum (optional for A2L).

This process shall be repeated until no refrigerant is within the system (optional for A2L).

When the final oxygen-free nitrogen charge is used, the system shall be vented down to atmospheric pressure to enable work to take place.

The outlet for the vacuum pump shall not be close to any potential ignition sources, and ventilation shall be available.

XXVI. CHARGING PROCEDURES (UL 60335-2-40)

In addition to conventional charging procedures, the following requirements shall be followed.

- Ensure that contamination of different refrigerants does not occur when using charging equipment.
- Hoses or lines shall be as short as possible to minimise the amount of refrigerant contained in them.
- Cylinders shall be kept in an appropriate position according to the instructions.
- Ensure that the REFRIGERATING SYSTEM is earthed prior to charging the system with refrigerant
- Label the system when charging is complete (if not already).
- Extreme care shall be taken not to overfill the REFRIGERATING SYSTEM.

Prior to recharging the system, it shall be pressure-tested with the appropriate purging gas.
The system shall be leak-tested on completion of charging but prior to commissioning.
A follow up leak test shall be carried out prior to leaving the site.

XXVII. DECOMMISSIONING (UL 60335-2-40)

Before carrying out this procedure, it is essential that the technician is completely familiar with the equipment and all its detail.

It is recommended good practice that all refrigerants are recovered safely.

Prior to the task being carried out, an oil and refrigerant sample shall be taken in case analysis is required prior to reuse of recovered refrigerant, is essential that electrical power is available before the task is commenced.

- a) Become familiar with the equipment and its operation.
- b) Isolate system electrically.
- c) Before attempting the procedure, ensure that:
 - Mechanical handling equipment is available, if required, for handling refrigerant cylinders;
 - All personal protective equipment is available and being used correctly;
 - The recovery process is supervised at all times by a competent person;
 - Recovery equipment and cylinders conform to the appropriate standards.
- d) Pump down refrigerant system, if possible.
- e) If a vacuum is not possible, make a manifold so that refrigerant can be removed from various parts of the system.
- f) Make sure that cylinder is situated on the scales before recovery takes place.
- g) Start the recovery machine and operate in accordance with instructions.
- h) Do not overfill cylinders (no more than 80 % volume liquid charge).
- i) Do not exceed the maximum working pressure of the cylinder, even temporarily.
- j) When the cylinders have been filled correctly and the process completed, make sure that the cylinders and the equipment are removed from site promptly and all isolation valves on the equipment are closed off.
- k) Recovered refrigerant shall not be charged into another REFRIGERATING SYSTEM unless it has been cleaned and checked.

XXVIII. LABELLING (UL 60335-2-40)

Equipment shall be labelled stating that it has been de-commissioned and emptied of refrigerant.

The label shall be dated and signed.

For appliances containing FLAMMABLE REFRIGERANTS, ensure that there are labels on the equipment stating the equipment contains FLAMMABLE REFRIGERANT.

XXIX. RECOVERY (UL 60335-2-40)

When removing refrigerant from a system, either for servicing or decommissioning, it is recommended good practice that all refrigerants are removed safely.

When transferring refrigerant into cylinders, ensure that only appropriate refrigerant recovery cylinders are employed.

Ensure that the correct number of cylinders for holding the total system charge is available

All cylinders to be used are designated for the recovered refrigerant and labelled for that refrigerant (i. e. special cylinders for the recovery of refrigerant).

Cylinders shall be complete with pressure-relief valve and associated shut-off valves in good working order.

Empty recovery cylinders are evacuated and, if possible, cooled before recovery occurs.

The recovery equipment shall be in good working order with a set of instructions concerning the equipment that is at hand and shall be suitable for the recovery of the flammable refrigerant. If in doubt, the manufacturer should be consulted. In addition, a set of calibrated weighing scales shall be available and in good working order. Hoses shall be complete with leak-free disconnect couplings and in good condition."

The recovered refrigerant shall be processed according to local legislation in the correct recovery cylinder, and the relevant waste transfer note arranged. Do not mix refrigerants in recovery units and especially not in cylinders.

If compressors or compressor oils are to be removed, ensure that they have been evacuated to an acceptable level to make certain that flammable refrigerant does not remain within the lubricant. The compressor body shall not be heated by an open flame or other ignition sources to accelerate this process. When oil is drained from a system, it shall be carried out safely.

1. Turn off the power supply to the Heat pump
2. Fully open the bypass valve and close the Heat pump inlet and outlet valves.

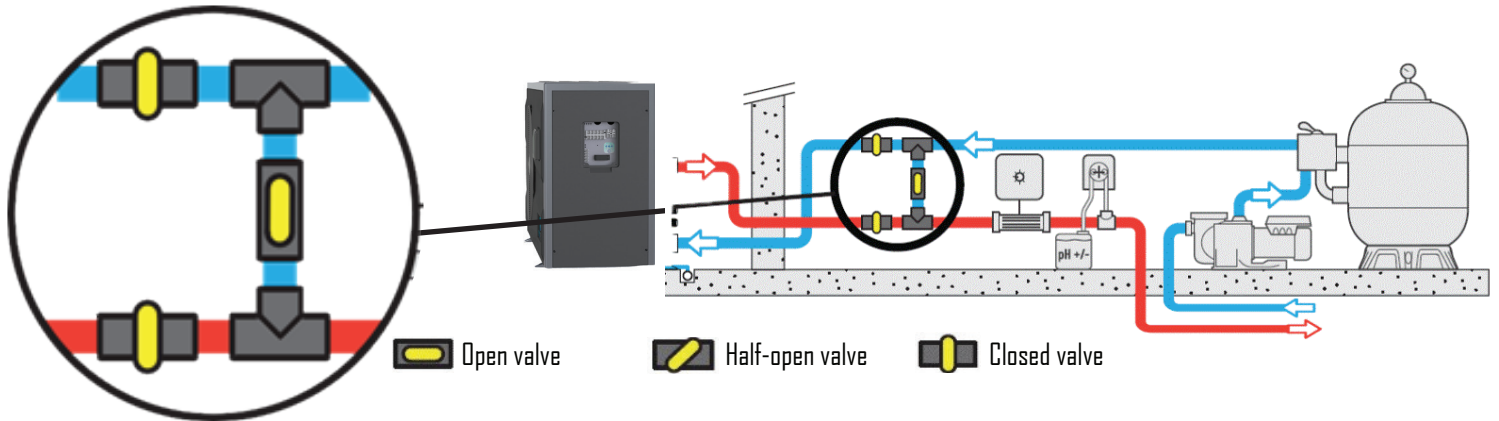

1. Unscrew the junctions to evacuate all the water contained in the Heat pump.
2. Reconnect and slightly tighten the junctions by hand to prevent the introduction of foreign objects into the Heat pump

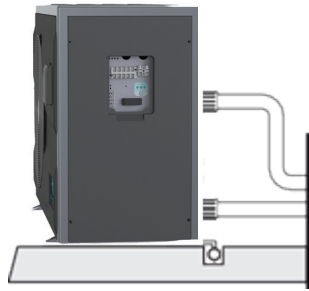
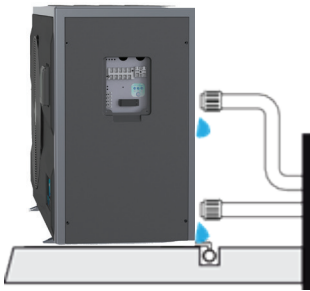

XXXI. RECYCLING THE HEAT PUMP

When your Heat pump reaches the end of its lifespan and you do not wish to keep it, do not throw it out with household waste.

The Heat pump must be brought to a selective recycling point for its reuse or recycling.

It contains potentially hazardous substances that may harm the environment and that must, during recycling, be eliminated or neutralised.

One of the following solutions should therefore be selected:



- Bring the Heat pump to a recycling center
- Give the Heat pump to a not-for-profit organisation so that it can be repaired and reused
- Give the Heat pump to the shop when buying a new unit

XXXII. AFTER-SALES TECHNICAL DEPARTMENT

In case of technical problems regarding any of the Tropical heat pumps, the following measures should be taken:

- Provide to the technical service the following essential information:
- Serial number of the machine
- Manometer value when machine is stopped
- Manometer value when machine is working
- The position of ON/OFF button and if it is lit or not
- The value and pictograms displayed on digital controller.
- The value of programmed settings
- If fan is working or not
- Position of the by-pass valves
- Contact your dealer and pass on this information together with the dimensions of the swimming pool, your personal details (address, telephone number) and the description of the failure.

If this procedure is respected, the Tropical technician will be able to make as accurate diagnostic of the failure.

The recommended solution made by Tropical will be implemented briefly after that.

IMPORTANT: If this measure is not followed, warranty will be cancelled.

Hotline : 1-727-823-5642